



Smart phone application (Bluetooth Option)



TF-100



TF-400

ZigBee Controller (Option)



Printer / Label printer (Option)

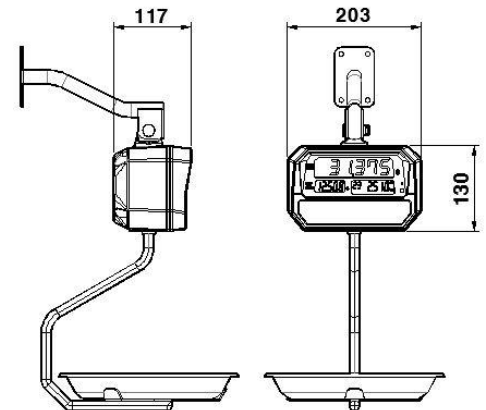

## FEATURE

- ◆ Water proof : IP-66
- ◆ Swivel hook
- ◆ Lightweight & easy to carry
- ◆ Big size display
- ◆ Built-in high capacity lithium polymer battery
- ◆ Wireless communication by using Bluetooth , ZigBee (Optional)

| MODEL             | TCC-15  | TCC-30      |
|-------------------|---|-------------|
| Capacity          | 7.5kg / 15kg  | 15kg / 30kg |
| Division          | 2g / 5g   | 5g / 10g    |
| Max. Tare Weight  | 15kg  | 30kg        |
| Product weight    | 2.8kg   |             |
| Display           | 6 digit, 24mm , 5digit. 14mm FSTN LCD / LED Backlight |             |
| Operating time    | Approx.200hr (Backlight off)                          |             |
| Battery           | Lithium Polymer Battery 3.7V                          |             |
| Temperature range | -10℃ ~ 40℃  |             |
| Keypad            | Power , Zero , Tare , Hold , PAY , SUM                |             |
| Display lamp      | Low Battery, Zero, Tare, Hold, Stable , UNIT Price    |             |
| Parts             | Charging Adaptor, Infrared remote controller          |             |
| Charging adaptor  | DC 5V, 1A SMPS  |             |
| Case material     | Engineering plastic                                   |             |