

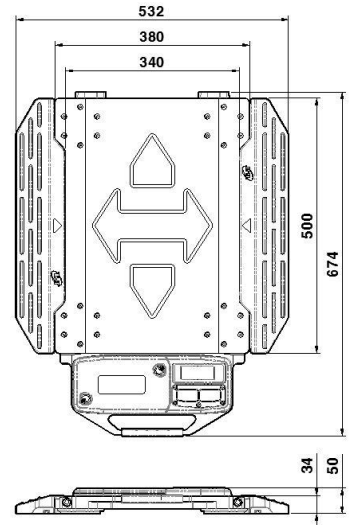

Battery pack



FEATURE

- ◆ Water Proof : IP-66
- ◆ Low platform height : 34mm
- ◆ Wireless Communication by using ZIGBEE
- ◆ Easy to change battery pack(Lithium Polymer Battery)
- ◆ Data communication with TXI-500F
- ◆ Possible to print out results by using TXI-500F

MODEL	TXD-501F	TXD-502F	TX-505F
Capacity	1,000kg	2,000kg	5,000kg
Division	1kg	2kg	5kg
Product dimensions (W x L x H)	674 x 532 x 50 (mm)		
Platform dimensions (W x L x H)	500 x 380 x 34 (mm)		
Product weight	17kg		
Operating time	60hr		
Power	3.7V Lithium Polymer Battery		
Key	ON/OFF , ZERO , SUM , BACK LIGHT		
Display	5digit LCD (height 15mm) back light		
Parts	Rechargeable adaptor , Lithium polymer battery pack		
Temperature range	-10°C ~ 40°C		