



TA-100, 500

TA-200



Smart phone application
(Bluetooth Option)



TF-100



TF-400

ZigBee Controller
(Option)



IR controller
(Standard)

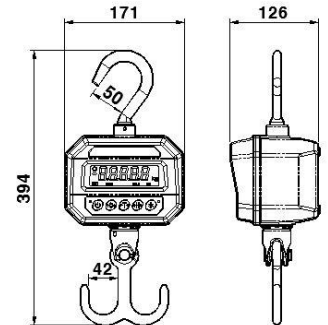
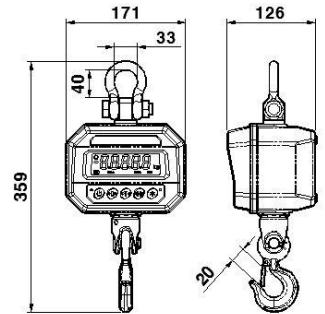

FEATURE

- ◆ Water Proof : IP-65
- ◆ Lightweight & easy to carry
- ◆ Easy to replace a used Shackle with a new one.
- ◆ Built-in high capacity lithium polymer battery.
- ◆ Infrared Remote Controller (Standard)
- ◆ Wireless communication by using ZigBee(Optional)
- ◆ As per purpose of using, it can divided into General Type (TA-500,100) and Meat Shop (TA-200)

MODEL	TA-100	TA-200	TA-500
Capacity	100kg	200kg	0 ~ 250kg / 250 ~ 500kg
Division	0.05kg	0.1kg	0.1kg / 0.2kg
Max. Tare Weight	100kg	200kg	500kg
Product weight	2.5kg		
Display	5 digit, 20mm LCD		
Operating time	Approx. 200hr		
Battery	Lithium Polymer Battery 3.7V		
Temperature range	-10℃ ~ 40℃		
Keypad	Power , Zero , Tare , Hold , * (Back Light)		
Display lamp	Low Battery, Zero, Tare, Hold, Stable		
Parts	Charging Adaptor, Infrared remote controller		
Charging adaptor	DC 5V, 1A SMPS		
Case material	Engineering plastic		